

# Service Information for the following brands: Champion, Porta Heat, Red Line, Century, Lawn Boy, Arctic Flame, Stones

## 3 Wire to 4 Wire PC Board Conversion on 60, 97, 150 Inline Low Pressure Heaters

**Disconnect the heater from any power source.**

1. After removing the defective PC Board install the new 4 wire PC Board in its appropriate location
2. Connect the white wire and yellow wire of the new PC Board to the same location as the white and yellow wire of the 3 wire PC Board
3. Connect the red wire of the PC Board to the #4 terminal of the relay.
4. Connect the blue wire of the PC Board to the #2 terminal of the circuit breaker.
5. Test the heater and attach the wiring diagram on appropriate location

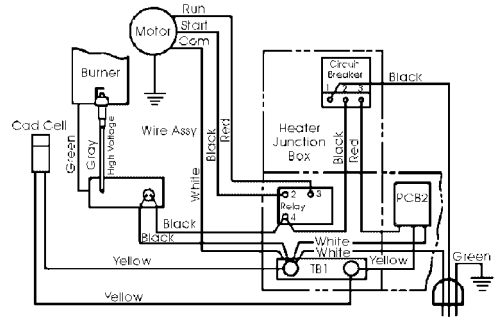

**4 Wire PC Board  
Wiring Diagram**

### Electrode Setting for M3981

Brands included: Master, Knipco, Reddy, Koehring

NOTE: The settings shown are for most conditions of fuel, humidity and temperature. You may find it necessary to increase the 1/8 inch setting to 3/16, in order to achieve good ignition and burning. The 1/2 inch dimension must be kept.

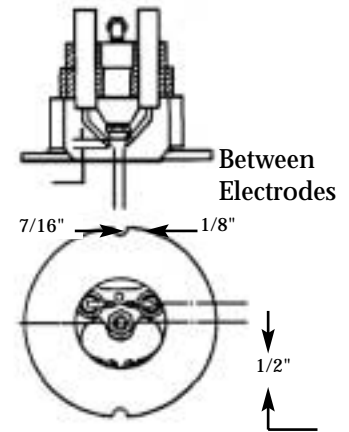

### AIR BAND ADJUSTMENT

Air band setting may vary slightly depending on fuel, climate and altitude. If your heater operates properly, you will have no reason to alter the factory setting. To set the air band, with the heater running, close the air band until only an occasional flicker is observed.

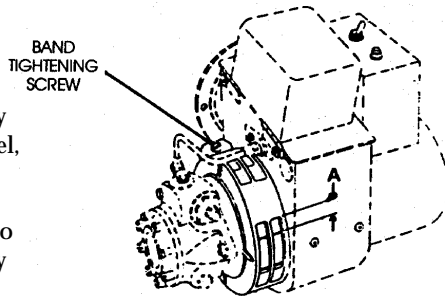

### APPROXIMATE FACTORY SETTINGS

Unit	Dimension "A"
<b>1725 RPM Burner</b>	
120,000 BTU	5/8"
155,000 BTU	1-13/16"
230,000 BTU	1-1/2"
<b>*3450 RPM Burner</b>	
155,000 BTU	1-5/16"
230,000 BTU	1-1/2"
<b>*High Speed Burner</b>	

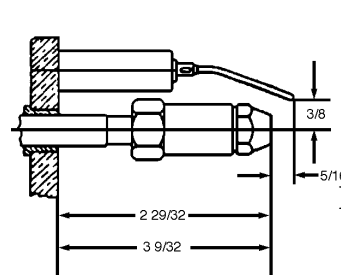
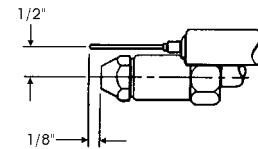
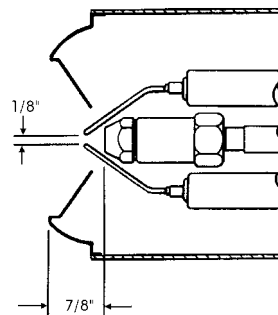

### Electrode Setting Air Scoop Heater ELECTRODE SETTINGS

Check electrodes for proper adjustment. The spark gap should be 1/8" (not to exceed 3/16") as shown. They should be 1/8" ahead of the nozzle face and 1/2" above the center of the nozzle. The relation of the electrodes to the nozzle and to the front end of the air cone is important.

